



GEMAC

Gesellschaft für
Mikroelektronikanwendung Chemnitz mbH



GEMAC mbH · Zwickauer Straße 227 · 09116 Chemnitz · Germany
Telefon: +49 371 3377 – 0 · Telefax: +49 371 3377 – 272
eMail: info@gemac-chemnitz.de · Web: www.gemac-chemnitz.de

1 Index

1 INDEX.....	2
2 INTRODUCING GEMAC.....	3
2.1 SALES REPRESENTATIVES AROUND THE WORLD:.....	5
2.1.1 Europe.....	5
2.1.2 Asia.....	6
2.1.3 South America.....	6
2.1.4 North America.....	6
3 ASIC-DESIGN	7
4 MEASURING SYSTEMS AND SENSOR DEPARTMENT.....	8
4.1 GENERAL.....	8
4.2 GEMAC'S FAMILY OF INTERPOLATION CHIPS.....	10
4.2.1 Structure of GEMAC Interpolation.....	10
4.2.2 Comparison GC-IP1000B, GC-IP200 and GC-AIP40.....	12
4.3 GEMAC INTERPOLATION SOLUTIONS.....	13
4.4 APPLICATION OF INTERPOLATION ELECTRONIC.....	15
5 MAGNETIC MEASURING SYSTEMS.....	16
5.1 GENERAL.....	16
5.2 GENERAL BASICS.....	16
5.3 MAGNETIC TAPE	17
5.4 READ HEAD.....	18
6 INCLINATION SENSORS.....	19
6.1 BUILT IN AND MODE OF OPERATION.....	20
6.1 FIELDS OF APPLICATION FOR INCLINATION SENSORS.....	22
7 FIELD BUS TESTER.....	23
7.1 GENERAL.....	23
7.2 CAN-BUS-TESTER 2.....	23
7.3 CANOBSERVER®.....	26
REFERENCE LIST.....	28

2 Introducing GEMAC

GEMAC, Gesellschaft für Mikroelektronikanwendung Chemnitz mbH, was established in 1992. Today we are more than 82 people. Turnover in 2008 will be around 10 Mio Euro = +25 %. Our R+D department with 38 certified engineers generates nearly 20% of the transaction volume, 40 % = OEM and 40 % own products.



Dr.-Ing. Claus Dittrich and Günther Schultze - General Managers of GEMAC

GEMAC is split in 5 departments:

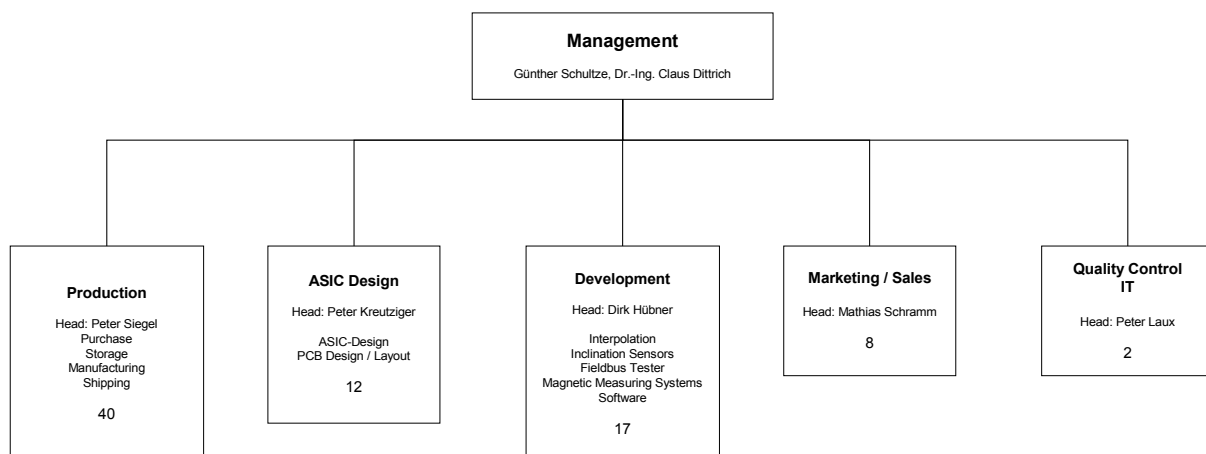

ASIC-Design

The ASIC-Design department includes 13 ASIC designers. We are able to adapt our products quick and perfectly suitable to the customers requirements.

Development

Our development department include 17 engineers. 7 of them are involved in product design and developing for GEMAC. The others are responsible for customized developments. We offers solutions in many fields: i.e medical engineering, sensors, industrial automation, measuring systems,...

Our main activities include customized development, programming, manufacture and testing of electronic systems, boards and components based on diverse technologies.

Main base for the growth are the own products.

Our special strengths are one-stop solutions, tailored to meet the specific needs of the customer. We can draw on a range of expertise in all fields of application-oriented microelectronic design which our specialists have been gathering since 1980:

- Circuit boards (conventional types, SMD, chip-on-board) design, assembly, testing
- Micro controllers / DSP - selection, application and programming
- Programmable logic (PLD, FPGA)
- Multichip modules, manufacture, testing
- Circuit development and ASICS design for digital and hybrid analogue/digital applications
- Microsystems technology - sensors, actuators, information processing
- Application-specific software development
- magnetic measuring systems

Besides OEM, we offer project-oriented expertise and technology transfer in order to assist companies when introducing and applying microelectronic and Microsystems technologies. From consultancy services for German and European projects via joint project planning right through to qualification programs for your company's specialists in the form of training courses and hands-on project work ("training on the project") – our customers receive every support which they can expect.

Our vast range of expertise covers primarily the "classic" applications of microelectronics. To a growing extend we are requested by our customers to develop for them rather exceptional applications for areas which have little to do with electronics, such as control and monitoring of wood-fuelled heating systems or leather tanning processes.

- Our portfolio also includes products from our own production, such as:
- Programmable electronic interpolation systems for measuring applications
- Interpolation circuits GC-AIP40, GC-IP200, GC-IP1000B
- Interpolation Units IPE40 up to IPE16000
- Inclination sensors, acceleration sensors, magnetic sensors
- CAN-BUS-tester and CANobserver®

Circuit boards, hybrid circuits or multichip modules developed by customers can also be produced by our company. Our component sales unit purchases the components which you need. And in the case of ASICS projects, we handle the transfer to the circuit manufacturer.

GEMAC mbH has implemented a quality system pursuant to DIN EN ISO 9001:2000 which was audited by BVQI Germany. We got the recertification at april 2008 and it is extended up to the year 2011.

2.1 Sales Representatives around the World:

2.1.1 Europe

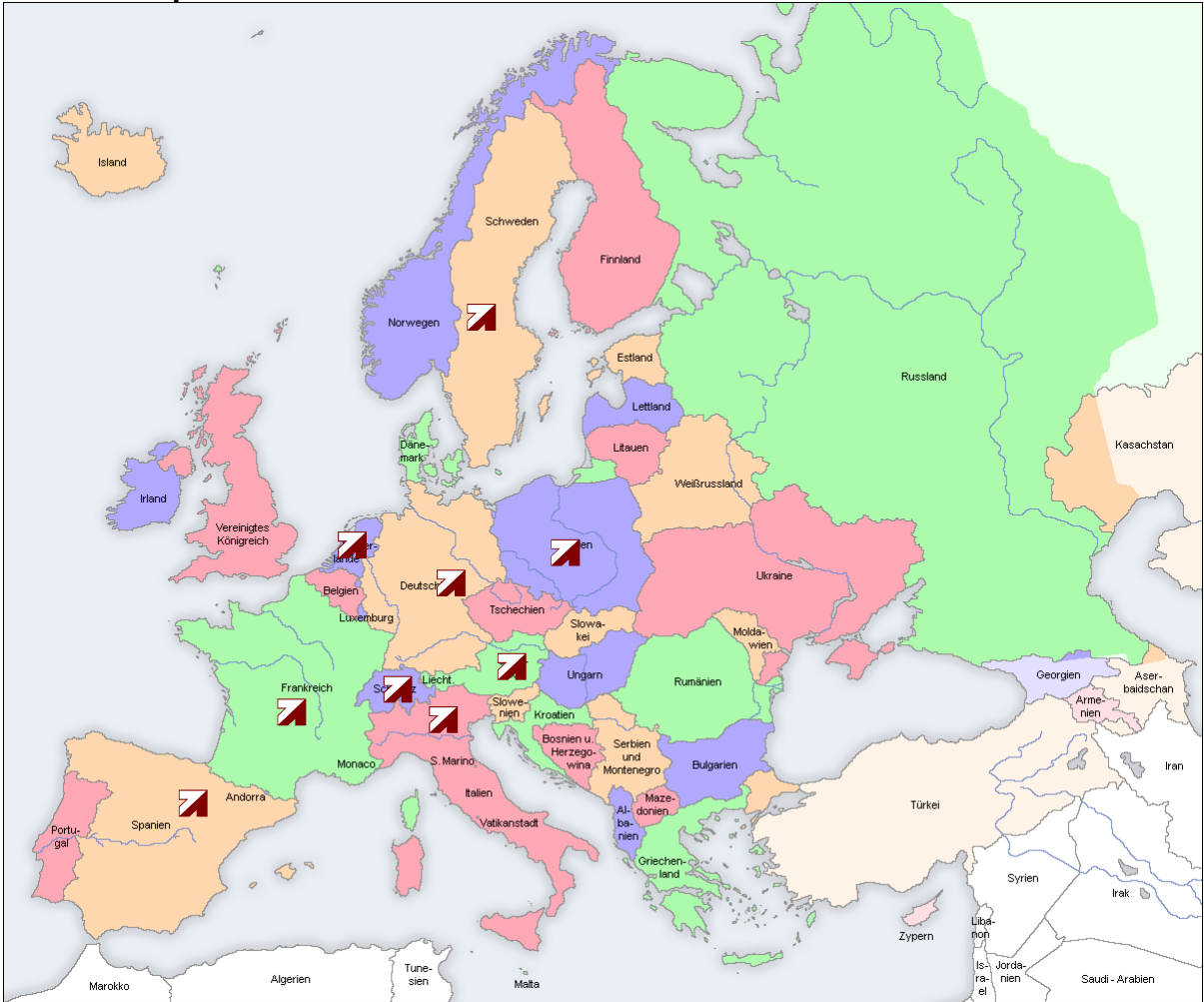

Representatives Europe

2.1.2 Asia



Representatives Asia

2.1.3 South America

Brazil

2.1.4 North America

Sarasota / Florida

3 ASIC-Design

The main potential of ASIC design at GEMAC is the development of so called mixed-signal ASIC's, a combination of analogue and digital functions in one chip. Such IC's will be used for sensor applications mostly.

Our designers work with the powerful Mentor Graphics development tools for IC design. It's one of the leaders in the market. Beside the development of our own IC's we offer our capabilities to our customers. Such customers comes from aerospace, aviation, IT automotive, medical and automation.

GEMAC handles with the complete development and production process. The customer don't need to deal with the hard to handle problems of the semiconductor process. The customer will get a ready manufactured and tested IC after finishing.

GEMAC offers

- Development of FPGA, Gate-Array and Standard-Cell-ICs
- Full Custom Design
- Analogue /digital ASICs
- Multiprojectwafer-Service (MPW)
- VHDL-Design

4 Measuring Systems and Sensor Department

4.1 General

The top product of GEMAC a family of interpolation circuits in the form of single-chip-solutions, the GC-AIP40, GC-IP200 and the GC-IP1000B. With those IC's it is possible to increase the resolution of angular or length measuring systems up to 1000fold.

At the input of those circuits a sine / cosine signal is required. These signals will be generated by the incremental trace of rotatory and linear measuring systems. There can be any kind of signal source, like optical rotary or linear encoders or systems based on the magnetically principle. Important are the two sine shaped signals with a phase shift of 90 degrees only.

The ASIC's amplify the analogue signals which were balanced by the gain and offset control procedure implemented in the circuit and sampled by a A/D converter which supplies a digital value at the output.

The maximum interpolation rate possible is forty (AIP40), two hundred-fold (GC-IP200) and one thousand-fold (GC-IP1000). The general structures and functions implemented in the ASIC are all programmable and can be adapted to the single application.

All measuring data can be read as a 90° phase shift square-wave pulse sequence or are simply transferred as standardised data over an interface. The ASIC provides also an integrated counting system, enabling data to be displayed or controlled. The compact design in a TSSOP20 resp. TQFP64 package enables the chips to be easily integrated into existing measuring or sensor systems.

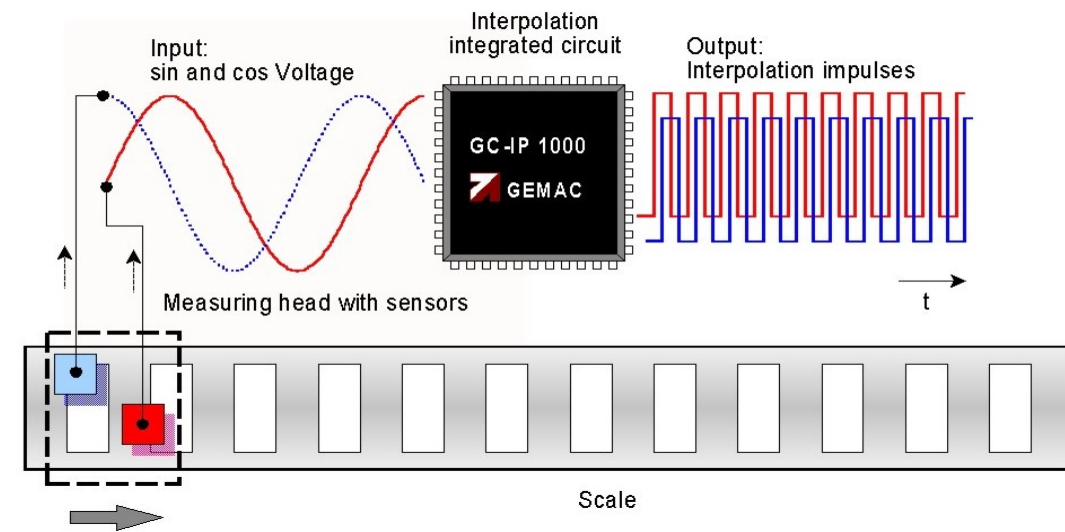

Figure 1 Interpolation

The input signal amplification is programmable. Also magnetoresistive sensors can connect without further outside amplification. The interpolated square wave signals as well as the value of the internal counter are available at the output. Through using the internal counter the maximum input frequency of the IC can be used. This is a big advantage against our competitors products. Here the highest interpolation rate can be used with limited input frequency only.

Usually the connected counter will limit the maximum input frequency in case of using the square wave outputs. Here is another advantage of our interpolation IC's. The edge distance of the square wave signals can be adjusted to the counter for avoiding miscounting. This is important for the maximum velocity and in case of stand still. For dimensioning of a system the complete signal flow from sensor to the counter is to consider. The counter has to be fast enough for counting all edges and also is it necessary to provide noise free signals.

Another critical point is the standstill of the axis. The position may jitter about 1 increment during the standstill. The edge distance will be much smaller than at maximum speed. If the pulses are faster than the following counter electronic miscounting can happens. In the result the counter value seems to be increased in spite of there is no moving. To avoiding this effect the interpolation IC will control the edge distance so that the minimum edge distance never will be underrun. The counter is able to follow all the jitters.

The main advantage of our interpolation IC's is the patented amplitude and offset regulation which is implemented in the IP200 and IP1000B. This system allows the automatic control of amplitude and offset changing in the range of $\pm 35\%$. So we can guarantee an accuracy of ± 1 Increment in a wide temperature and dynamic range. Our 40fold interpolation IC AIP40 is an extreme small and also cheap interpolator which can be used manifold. It's maximum input frequency of 1.2MHz makes essential everywhere where fast moving have to be measured and controlled very precise. Due to it's analogue structure it is a real time system. So the AIP40 is an optimum solution for continuous-path controls, direct measuring in drives, handling systems or in printers.

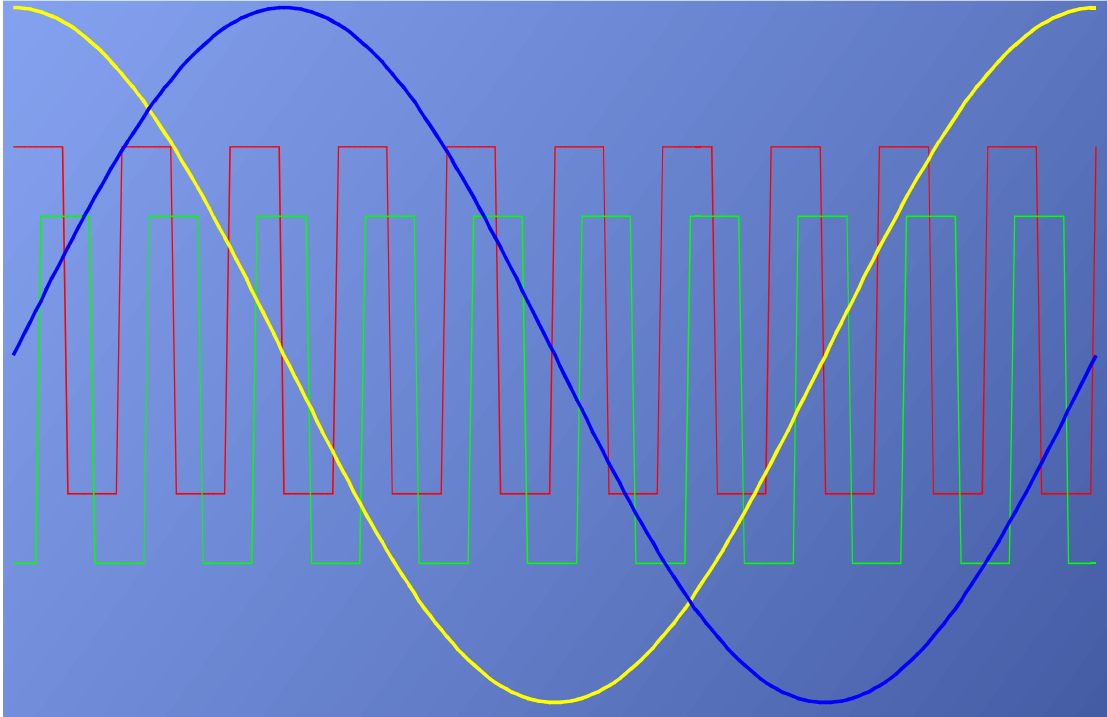

Figure 2 Schematic of interpolation

4.2 GEMAC's Family of Interpolation Chips

GEMAC has developed a family of interpolation circuits in the form of one-chip-solutions, the GC-AIP40, GC-IP200 and the GC-IP1000B. The ASIC's amplify the analogue signals produced by the sensors at the measuring feelers. Subsequently, the reading is then modulated. According to the rate of interpolation employed the measuring data can be further fragmented. The maximum fragmentation possible is forty, two hundred-fold with GC-IP 200 and one thousand-fold with a GC-IP 1000. The general structures and functions implemented in the ASIC are all programmable and can be adapted to the single application.

The output of the sensor elements (sin/cos signals) are amplified, balanced by the gain and offset control procedure implemented in the circuit and sampled by a A/D converter which supplies a digital value at the output. Depending on the interpolation rate chosen the scale values of the measuring unit implemented in the system are refined accordingly.

All measuring data can be read as a 90° phase shift square-wave pulse sequence or are simply transferred as standardised data over an interface. The ASIC provides also an integrated counting system, enabling data to be displayed or controlled. The compact design in a TQFP-package (size 10mmx10mmx1mm) with 64 pins enables the chips to be easily integrated into existing measuring or sensor systems.

By integrating the ASIC into the measuring head the user can achieve a higher resolution up to the factor 1000 keeping the system dimensions unchanged.

The complete integration of an interpolation system in one ASIC and especially the technical parameters of the solution have already convinced a lot of customers. GEMAC chips are working successfully in a lot of applications of leading manufacturers of machine tools and packaging machines, or in robots and could be used in anti-lock braking systems as well.

4.2.1 Structure of GEMAC Interpolation

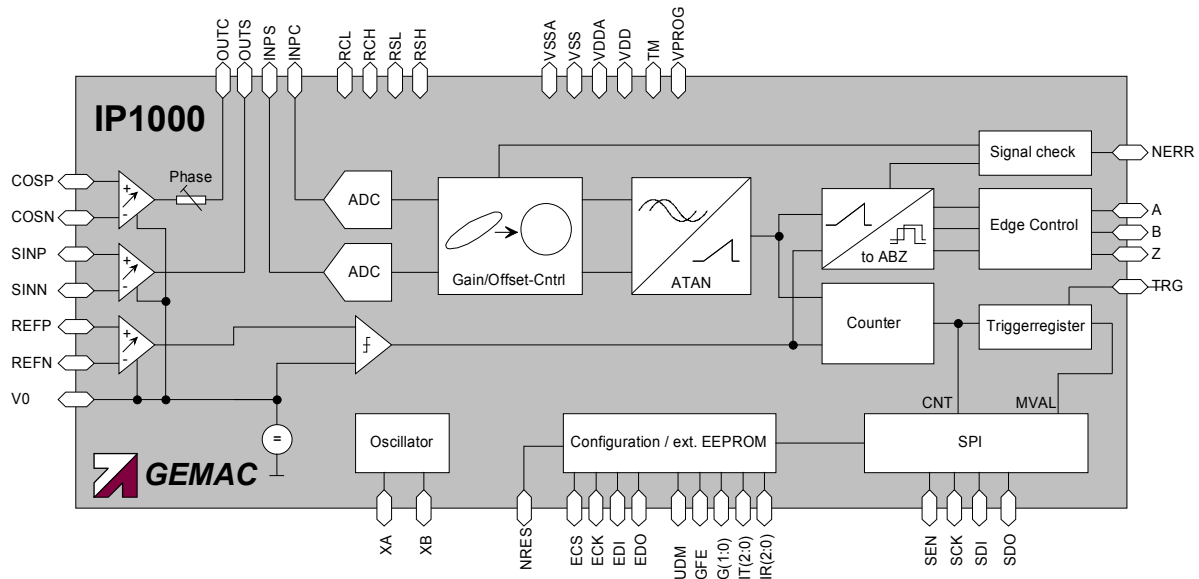

Figure 3 Block diagram GC-IP1000

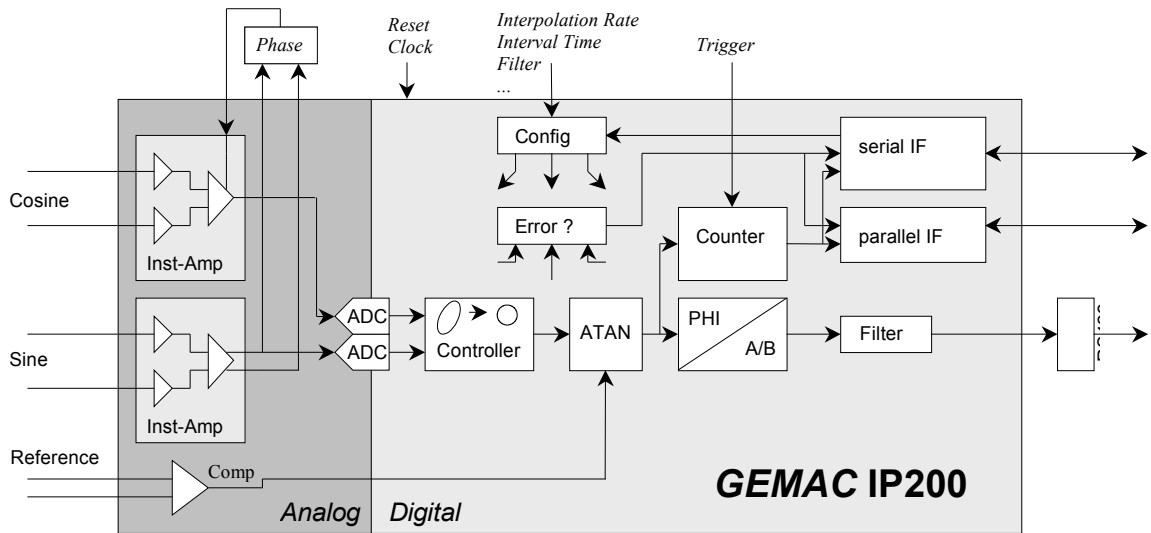

Figure 4 Block diagram GC-IP200

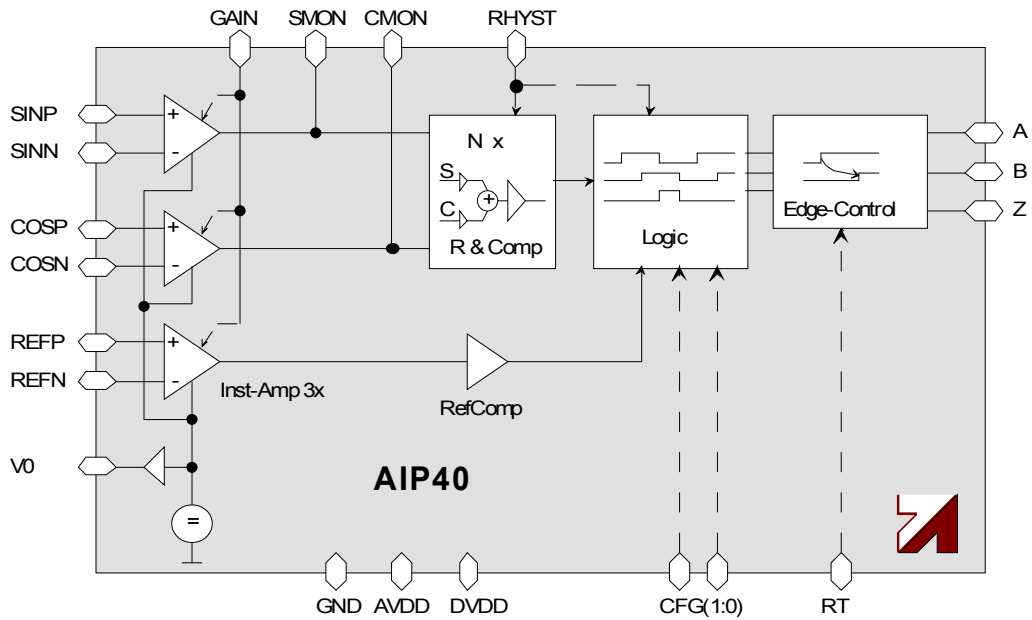

Figure 5 Block diagram GC-AIP40

4.2.2 Comparison GC-IP1000B, GC-IP200 and GC-AIP40

	GC-IP1000B	GC-IP200	GC-AIP40
Analogue Input	<ul style="list-style-type: none"> ➤ 3 channels differential: sine/cosine/reference signal ➤ Standard connection 1V_{PP} (differential) ➤ Input ranges: 100mV_{PP}, 120mV_{PP}, 145mV_{PP} (differential) ➤ Single-ended input 2.0V_{PP} ➤ Input frequency of up to 110kHz 	<ul style="list-style-type: none"> ➤ 3 differential channels: sine/cosine/reference signal ➤ Standard connection 1V_{PP} (differential) ➤ Input frequency of up to 333kHz ➤ Single-ended input 2.4V_{PP} ➤ Input frequency of up to 400kHz 	<ul style="list-style-type: none"> ➤ 3 channels differential: sine/cosine/reference signal ➤ Standard connection 1V_{PP} (differential) ➤ Input ranges: 100mV_{PP}, 530mV_{PP}, 666mV_{PP} (differential) ➤ Input frequency of up to 1.2MHz
AD converter	<ul style="list-style-type: none"> ➤ Internally 340 kS/s max. ➤ External option 	<ul style="list-style-type: none"> ➤ 1MS/s ➤ Single-Ended Input 2.4V_{PP} 	
Signal correction	<ul style="list-style-type: none"> ➤ Automatic offset and amplitude controller ➤ Digital potentiometer for phase 	<ul style="list-style-type: none"> ➤ Automatic gain and offset controller ➤ External potentiometer for analogue phase correction 	
Interpolation rates	<ul style="list-style-type: none"> ➤ 1000, 800, 500, 400, 250, 200, 125, 100 	<ul style="list-style-type: none"> ➤ 200, 160, 100, 80, 50, 40, 25, 20 	<ul style="list-style-type: none"> ➤ 40, 32, 20, 16, 8, 4
Outputs	<ul style="list-style-type: none"> ➤ 28-bit counting value ➤ 90° square-wave sequences or up/down counting pulses, resp. ➤ Error signal 	<ul style="list-style-type: none"> ➤ 28 - Bit counter ➤ 90° - square wave sequences ➤ Error signal 	<ul style="list-style-type: none"> ➤ 90° square-wave sequences counting pulses
Configuration options	<ul style="list-style-type: none"> ➤ Via configuration pins ➤ Via serial interface (SPI) ➤ Via EEPROM 	<ul style="list-style-type: none"> ➤ Via configuration pins ➤ Via serial interface (SPI) 	<ul style="list-style-type: none"> ➤ Via configuration pins
Serial interface (SPI)	<ul style="list-style-type: none"> ➤ For configuration and measuring-value output ➤ 16-bit synchronous/asynchronous mode ➤ Not required for minimum configurations 	<ul style="list-style-type: none"> ➤ For Configuration and measuring value output ➤ 16-Bit synchronous/asynchronous mode ➤ Not required for low-cost minimal applications 	
Parallel output		<ul style="list-style-type: none"> ➤ 16-Bit wide ➤ Up to 32MB/s bandwidth 	
EEPROM	<ul style="list-style-type: none"> ➤ Up to 8 configuration banks ➤ For controller settings (gain / offset / phase) ➤ In conjunction with SPI, for any user data ➤ Not required for minimum configurations 		
Miscellaneous	<ul style="list-style-type: none"> ➤ Filter for suppressing edge noise at low speeds ➤ Programmable interval time for adapting the IC to slower electronic ➤ Edge-controlled measuring-value trigger ➤ Programmable response of the IC to sensor errors 	<ul style="list-style-type: none"> ➤ Filter for suppressing edge noise at low speed input signals ➤ Programmable interval time for adapting the IC to slower electronic ➤ Two-level edge-controlled measuring trigger ➤ Programmable sensor error response 	<ul style="list-style-type: none"> ➤ Programmable hysteresis for suppressing edge noise at low speed input signals ➤ Programmable interval time for adapting the circuit to low speed
Package	<ul style="list-style-type: none"> ➤ TQFP64 (10mm x 10mm x 1mm) or DIE 	<ul style="list-style-type: none"> ➤ TQFP64 (10mm x 10mm x 1mm) or DIE 	<ul style="list-style-type: none"> ➤ TSSOP20 or DIE

Table 1 Comparison of GEMAC interpolation IC

4.3 GEMAC Interpolation Solutions

Based on the interpolation IC's as well as special solutions with DSP's and FPGA's GEMAC produces PCI-card and measured value processing units with interpolation rates up to 16384 also. These systems can be configured with up to 16 interpolation or counter channels. 3 and 6 channel measured value units are standard. Typical application is the interpolation and positioning in machine tooling and automotive sector.

Interpolation electronics and components provided by GEMAC



Figure 6 IPE200-U

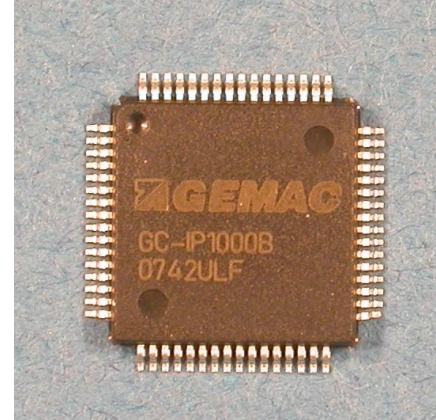

Figure 7 GC-IP1000B

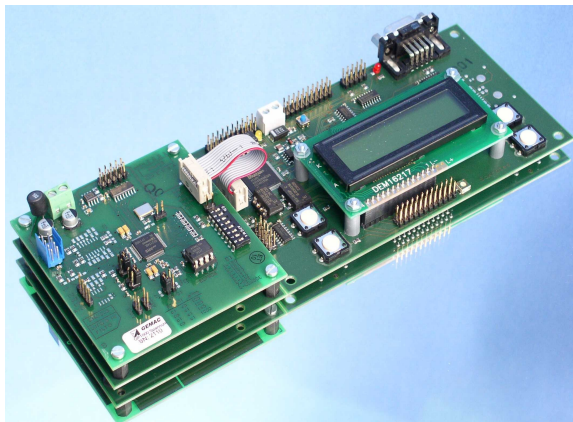

Figure 8 Sokrates + GP1000U

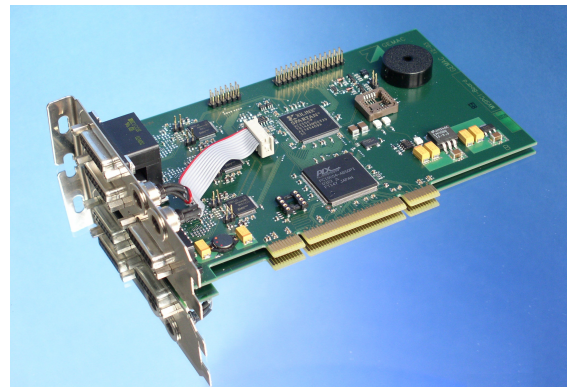

Figure 9 MVSPCI

Interpolation Circuits	GC-AIP40, GC-IP200, GC-IP1000B																				
Demonstration boards	GP40, GP200, GP1000IU																				
Applications / Products	<table border="0"> <tr> <td>IPE40</td> <td>- one channel stand alone unit</td> </tr> <tr> <td>IPE200-U/I</td> <td>- one channel stand alone unit</td> </tr> <tr> <td>IPE1000-U/I</td> <td>- one channel stand alone unit</td> </tr> <tr> <td>IPM2000</td> <td>- one channel interpolation board</td> </tr> <tr> <td>IPM4000</td> <td>- one channel interpolation board</td> </tr> <tr> <td>IPE16000</td> <td>- up to 8 channel interpolation stand alone unit</td> </tr> <tr> <td>MVS7</td> <td>- 6 +1 channel stand alone unit</td> </tr> <tr> <td>ZKPCI</td> <td>- 3 channel counter PC-Card</td> </tr> <tr> <td>MVSPCI</td> <td>- 3 channel interpolation and counter PC-Card</td> </tr> <tr> <td>AZ1000</td> <td>- fast counter unit</td> </tr> </table>	IPE40	- one channel stand alone unit	IPE200-U/I	- one channel stand alone unit	IPE1000-U/I	- one channel stand alone unit	IPM2000	- one channel interpolation board	IPM4000	- one channel interpolation board	IPE16000	- up to 8 channel interpolation stand alone unit	MVS7	- 6 +1 channel stand alone unit	ZKPCI	- 3 channel counter PC-Card	MVSPCI	- 3 channel interpolation and counter PC-Card	AZ1000	- fast counter unit
IPE40	- one channel stand alone unit																				
IPE200-U/I	- one channel stand alone unit																				
IPE1000-U/I	- one channel stand alone unit																				
IPM2000	- one channel interpolation board																				
IPM4000	- one channel interpolation board																				
IPE16000	- up to 8 channel interpolation stand alone unit																				
MVS7	- 6 +1 channel stand alone unit																				
ZKPCI	- 3 channel counter PC-Card																				
MVSPCI	- 3 channel interpolation and counter PC-Card																				
AZ1000	- fast counter unit																				

The newest products are the interpolation unit IPE16000 and the interpolation modules IPM2000 and IPM4000. The IPM4000 offers a maximum input frequency of 330kHz and an maximum interpolation rate of 4096. Unique is the very low delay rate of less than 4µs for the time between the sample of the encoder signals and showing the measurements. It's applicated perfectly in closed systems. The IPE16000 offers highest dynamic at highest measuring accuracy. The maximum input frequency is 500 kHz and the maximum sample rate 2 MS/s. We can guarantee an accuracy of ±0.5 Increment. Unique ist he patented automatically gain, offset and phase correction. The IPE1600 is used up to eight channels, and it is a 1/2 19 inch system.

Conclusion

Requirements

For using an interpolation 2 sine-shaped output signals (current or voltage) with a 90° phase shift are required.

Issue of Interpolation

Main issue of an interpolation is an additional splitting of the input signal period with the goal to increase the measuring resolution.

Application of Interpolation electronics

Interpolation electronics can use in consumption with incremental sensors for angular- and position measuring systems. That means it is possible to use optical as well as magnetically sensors.

Please note!

An interpolation cannot make a measuring system more accurate! It only can increase it's resolution. But the scale errors cannot be corrected. That's why a good quality of the scale is very important.

4.4 Application of Interpolation Electronic

Incremental length and angular measuring systems are used for the precise control of linear movements or rotation and to adjust exactly a predefined position. These requirements exist in a lot of technical applications, e.g. in the area of machine building and industrial engineering, especially for measuring devices and applications in the automotive industry and the railway sector.

The measuring devices work on the base of mechanical, optical, magnetic or capacitive processes. In all cases, the measuring results are based on a scale. It's smallest intervals define the resolution of the measuring system. However, the costs for such a system increase with a growing resolution and precision of the scale dramatically. A compromise which combines the advantages of a finer scale with a high precision on the one side with a reasonable system price on the other side, is the system implementation of an interpolation chips.

Potential customer:

- Producer of measuring systems (rotary encoders, linear scales)
- Producer of drive systems
- Control systems
- Sensor producer
- Producer of hydraulic and pneumatic systems
- Producer of positioning systems
- Producer of measuring machines and co-ordinate machines
- Inspection and testing equipment,
- Robots and handling systems, transportation systems, lifts
- Producer of printers and plotters
- Automotive

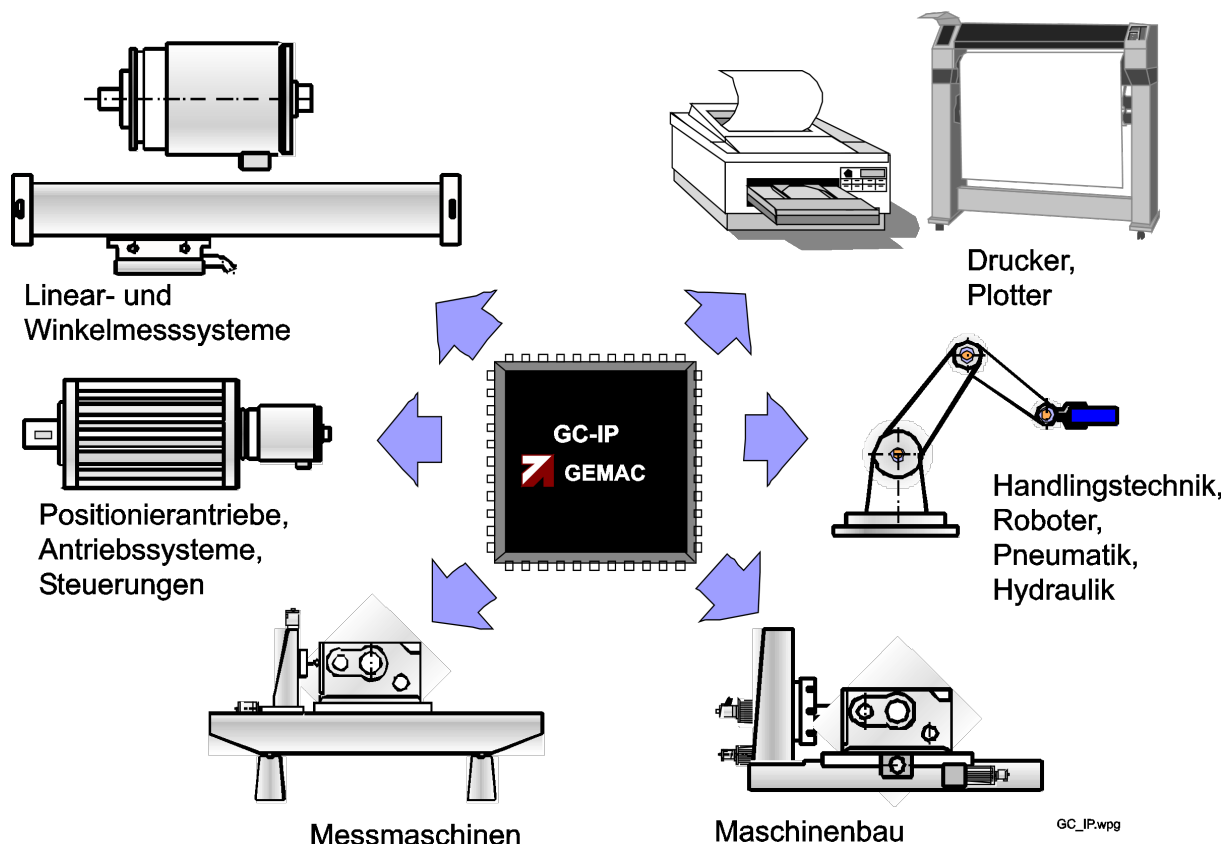

Figure 10 Applications of interpolation

5 Magnetic Measuring Systems

5.1 General

The development of the interpolation IC's was very helpful for the expansion of magnetic measuring systems. The resolution of magnetic scales usually is in the range of 1mm up to 5mm. This is insufficient for most applications. By using a 1000fold interpolation rate with GEMAC IC's the resolution can be increased to 1 μ m resp. 5 μ m. By this way the magnetic measuring systems becomes a alternative to the optical systems. The systems can reach for many application in the machine tooling sector now. A big advantage of the magnetic systems against the optical is the insensitivity to dust. They work perfectly also in case of dust from wood working machines or in a oil bath. A optional cover tape protect the scale. But the main advantage is the low price compared with the optical measuring systems.

The automatic gain and offset regulation makes our interpolation IC's suitable for magnetic measuring systems. The input signals will be adjust optimal during work. So the higher temperature dependence can be compensate. Important is also the air gap between sensor and scale. In case of larger moving ranges it is possible that the air gap is not constant. The regulation compensates the influences and guarantee a stable measuring result. The sensor chip can be connect to interpolation IC directly without any additional amplifier. This is another feature of the interpolation IC's AIP40 and IP1000B which makes a very compact construction possible. In consequence the resolution of the out coming signal is in the micrometer range.

Fields of application of such measuring systems are machine tooling, wood working machines, robots, handling systems, automation and measuring machines as well as controls of linear modules.

There is a increasing demand to cheap magnetic linear sensors for controlling of hydraulic and pneumatic plungers and cylinders.

5.2 General Basics

The magnetic measuring systems of the GC-MK-series are suitable for linear position detection. They are incremental systems. The maximum reachable resolution depends on the configuration and will be up to 1 μ m with those systems. So a absolute accuracy of 10 μ m is possible. At the same time the repeatability is also 1 μ m.

The contactless measuring principle makes the systems suitable for high dynamic processes in drive applications. The main advantages against the more expensive optical systems is the insensitivity to dust. So the measuring systems can be used in dirty environments.

The modular structure of the GC-MK-series makes the mounting and using very easy. The magnetic scale will be mount with double-side adhesive tape directly to the machine. The signal conditioning and processing which is integrated in the read head a easy and comfortable installation can be done.

The systems provides square waves via a standardised RS422 interface. It is possible to get the read head with modified edge distances for adapting to slower counter.

5.3 Magnetic Tape

The magnetic tape is the scale of the system. It is magnetised in defined distances. The basis material is an elastomer tape which is very resistant against high temperatures and several chemical substances. It is mount on a high-grade steel tape. This combination can be used in the machine tooling. The linear expansion coefficient is nearly the same like steel.

An additional high-grade steel cover tape makes the mechanical protection complete. The cover tape is optional.

Both tapes will be mount by a pre installed double-side adhesive tape.

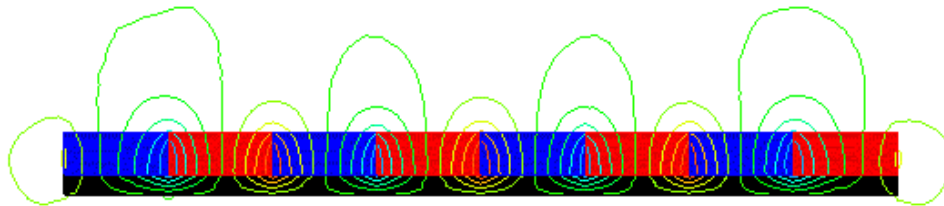

Figure 11 magnetically field of a magnetic tape

Basic Features

- Suitable for the read heads GEMAC read heads
- Elastomer film on CrNi 17 7 high grade steel
- Insensitive against corrosion
- High temperature stability
- Insensitive against several chemical substances

Technical Parameter

Pole Length	1mm, 2mm, 5mm
Width	10mm
Length	Standard 30m, max. 100m
Accuracy Class	± 40µm/m
Linear Expansion Coefficient	$(11\pm 1) \times 10^{-6}/K$
Material	Elastomer Metal Bond
Operating Temperature Range	-40°C to +120°C
Storage Temperature Range	-40°C to +120°C

Table 6

Distance Sensor – Tape	Max. 0.5mm, 1mm, 2.5mm
Cover Tape*	High Grade Steel
Mounting	adhesive sealing

Table 7

5.4 Read Head

The magnetic information of the scale GC-MB will be detected by the read head contactless. An integrated interpolation IC makes a resolution of up to 1 μ m possible. Via an RS422 interface the length information will be provided for a further processing.

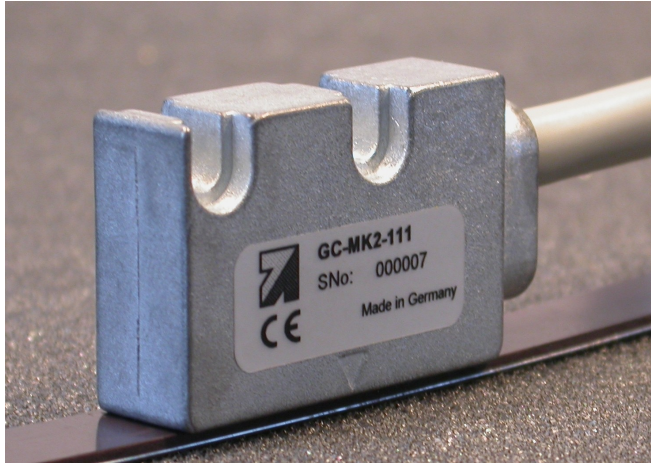

Figure 12 Read head

Features:

- Pole length 1mm, 2mm, 5mm
- Different resolutions available
- Different edge distances available
- Metal case
- Degree of protection IP67

Technical Parameter

Power Supply	5VDC
Output Signals	RS422
Connector	Standard without connector Sub-D15 male connector optional
Degree of Protection	IP67
Temperature Range	-20 to +85°C
Housing	Metal
Cable Length	1m *

Table 2

Resolution	Up to 1 μ m
Min. Edge Distance	Standard 250ns ; optional 500ns, μ s, 2 μ s, 4 μ s, 8 μ s
System Accuracy	$\pm (0,04 + 0,002)$ mm/m (magnetization accuracy + interpolation error)
Repeatability	± 1 Increment
Max. Velocity	max. 25m/s

Table 3

Output Signals

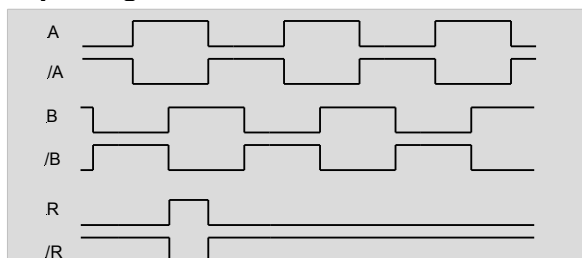

Figure 13

Adapting to a Counter

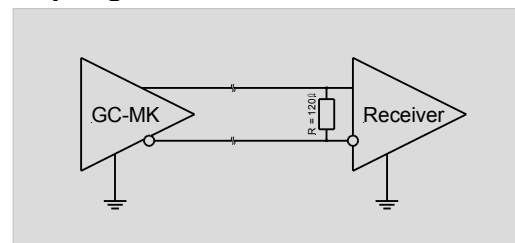

Figure 14

6 Inclination Sensors

The main features of the GEMAC inclination sensors:

- Ability to use in Bus systems,
- Standard industrial interfaces,
- Usable under hard environments,
- Usable in critical application due to error control and diagnosis

That the reason why the sensors can be used in many different applications like controls, measuring devices, automotive, railway vehicles, building machines and special vehicles.

Usually the sensors consist of an ASIC in combination with a micro mechanical sensor element. The sensor element is a movable silicon sensor structure between two electrodes on glass. It will be called bulk micro mechanical. The dimensions of such elements are usually from 5 to 8mm.

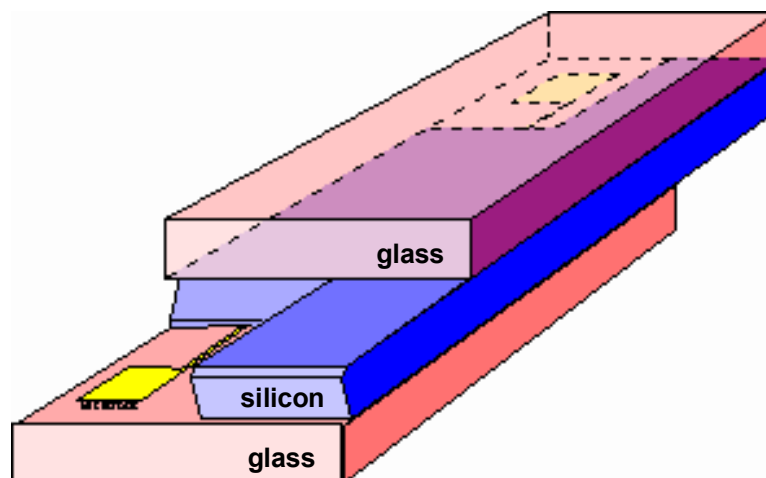

Figure 15 Sensor element structure

A new upcoming field is the surface micromachine technique. The dimensions could be reduced and so the production cost also.

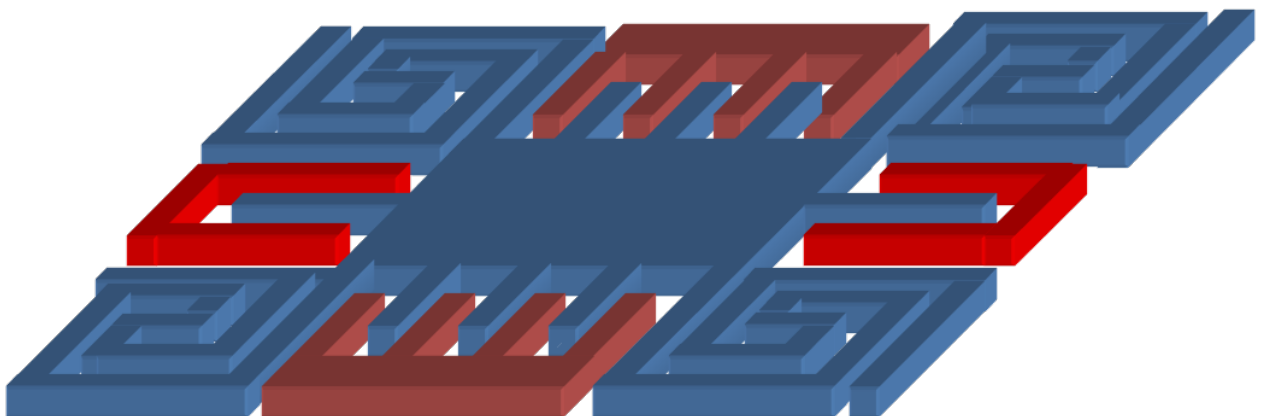

Figure 16 Sensor element in surface micromachine technique

The necessary active area of the electrode will be reached by the comb-shaped structure.

A very important section of clients are producers of building, agricultural and harvesting machines. The robust structure in silicon, which is resistant against shock in the range about 1000g, is very suitable for such applications. The sensors are equipped with usual interfaces like voltage or current or CAN Open. So it is possible to implement these parts very fast and simple in existing systems.

6.1 Built in and Mode of Operation

The inclination measurement based on the measuring of the acceleration due to gravity

$$g_{inc} = g \cdot \sin\alpha$$

which influence the seismic bulk in case of an inclination from the upright position. The bulk is hanging on springs. This element is the middle electrode of a differential capacitor (see figure below). Plates of glass with metallic structures are the fix electrodes of this capacitor.

The detuning of the capacitor ΔC_D caused by inclination or an acceleration in Z-direction at the right angle to X,Y-plane of the sensor element.

$$\Delta C_D = C_1 + \Delta C_1 - (C_2 - \Delta C_2) \cdot \Delta C_D$$

$\Delta C_1, \Delta C_2$: Changing of the capacity of C_1 and C_2

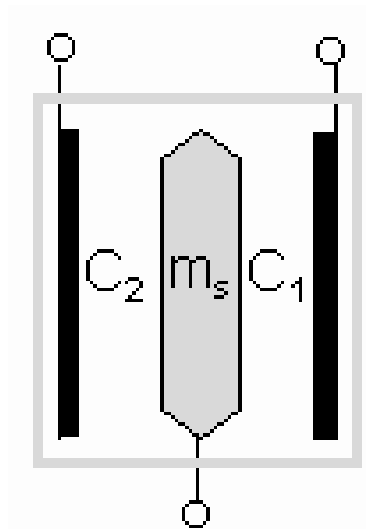

Figure 17 Differential capacitor principle

Series of inclination sensors:

- 1 and 2-dimensional with analogue current- or voltage output
- 2-dimensional digital inclination sensors with CAN- resp. CANopen output
- 2-dimensional digital inclination sensors with CAN- resp. CANopen switch outputs

Due to the construction of the sensors they have a high accuracy and a high long time stability and reliability. The robust aluminium case (IP65, 67) and the high working temperature range allows the use under hard conditions.

Examples for different housing solutions



Figure 18 inclination sensor 360°

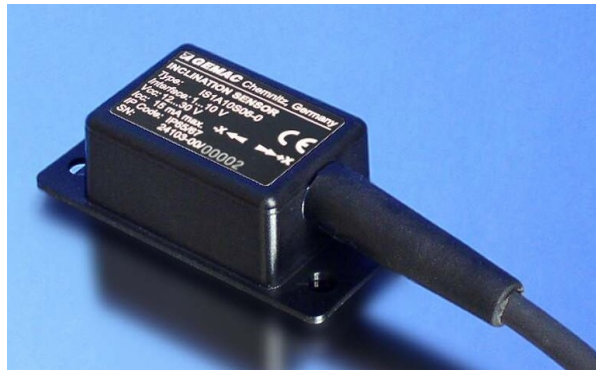

Figure 19 inclination sensor 7.5°



Figure 20 inclination sensor special housing



Figure 21 inclination sensor plastic housing

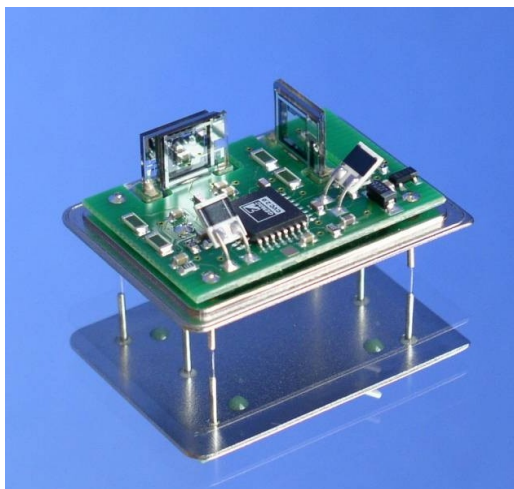

Figure 22 inclination sensor 2D-ISA

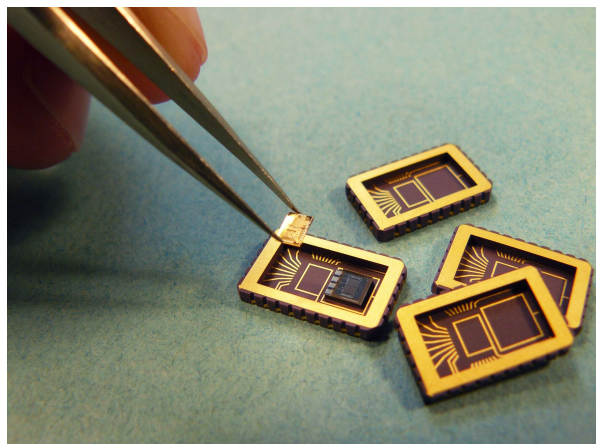

Figure 23 vibration sensor VibSens

6.1 Fields of Application for Inclination Sensors

- Mobile agriculture and construction machines
- Loading and transportation equipment
- Inspection equipment for bridges
- Rescue equipment
- Ship building



Figure 24 Sugar Beet Harvester



Figure 25 Hydraulic Platforms



Figure 26 Reach Trucks / Fork Lifts



Figure 27 Work Platforms



Figure 28 Cranes



Figure 29 Road construction machines



Figure 30 Inspection equipment



Figure 31 Excavator

7 Field Bus Tester

7.1 General

The capability of modern complex systems like production, chemical and storage lines will be determined by field bus systems like Profibus, CAN-Bus and DeviceNet. The complete communication will be done via field busses. System errors in the system are able to bring it to a critical level. From experience mostly the error reason is on the physical layer. With the CAN-Bus and DeviceNet testers of GEMAC the user is able to find and analyse these errors. With the integrated logging functions long time measuring can be done. So temporary errors can be found.

A big advantage of our tester is its capability to measure online. So the production line can run during the measuring. The testers were developed for using through the stuff without any special knowledge.

There are high positive economic effects because it is not necessary to switch off the system. So the time to set a systems into operation will be reduced. Errors can be detected very early due to the permanent monitoring.

7.2 CAN-Bus-Tester 2

The CAN-Bus-Tester 2 (CBT2) permits a draft start-up and a stable operation of CAN-Bus systems. Beside the protocol analyses you can identify problems on the physical bus level by measuring the disturbance-free voltage at run time. A low disturbance-free voltage range is caused by bus problems at the physical level. A low disturbance-free voltage range indicates an insufficient resistance of your bus to EMC influences, for example.

A **high disturbance-free voltage range**, in contrast, represents an interference resistant system which saves you substantial costs and trouble caused by system failures. The outstanding user-friendly system enables you to select different test modes for analysing your bus with regard to a variety of characteristics, such as:

- overview of the disturbance-free voltage range of all telegrams
- more detailed analysis of a selectable telegram
- logger function for long-time analyses
- several trigger conditions for identifying faults and errors
- extended displaying of the IDs is available for DeviceNet or CANopen



Figure 32 CAN-Bus-Tester 2

TECHNICAL SPECIFICATIONS

General parameters and overview of functions	
Use (CAN type)	CAN (ISO11898-2), CANopen, DeviceNet (EN 50325-2)
Bit sampling	64-fold, 10,240 sampling points
Supported baud rates	<ul style="list-style-type: none"> Depending on CAN type: 10; 20; 50; 100; 125; 250; 500; 800; 1000 kbit/s Additionally user-defined: 5; 33,3; 62,5; 75; 83,3 kbit/s Automatic detection via baud rate scan
List of stations	<ul style="list-style-type: none"> Automatic detection via Station scan Designation, CAN ID, ID type, Node ID, MAC ID can also be entered manually
List of Measurements	<ul style="list-style-type: none"> Possibility to measure at different measuring points and at different times Sorting by measurement type, measuring point and measurement time
Quality level	<ul style="list-style-type: none"> Value representing the signal quality (0 ... 100%) Minimum value and maximum values saved Time stamp
Disturbance-free voltage range and edges	<ul style="list-style-type: none"> Disturbance-free voltage range (typ. -0,75 ... 3 V, resolution 50 mV) Edge steepness (falling and rising, specified in 1/64th of the bit width) Minimum value and maximum values saved
Oscilloscope display	<ul style="list-style-type: none"> Trigger on message frames with specified ID, trigger position can be set Frame analysis and full frame recording Decoding according to protocol (CAN, CANopen, DeviceNet) Zoom (six stages)
Online trigger	<ul style="list-style-type: none"> Real-time monitoring of the bus for logical and physical errors Resolution can be set (10 ms ... 1 min) Oscilloscope display and e-mail notification on triggers
Automatic evaluation	Limit value settings and measured-value evaluation according to: <ul style="list-style-type: none"> critical quality level critical disturbance-free voltage range critical edge (rising and falling)
Bus status	Bus traffic detection (display: dominant, recessive, not defined, bus traffic)
Bus traffic load	<ul style="list-style-type: none"> Permanent display of the bus traffic load (0 ... 100%), Minimum and maximum values saved
Error frames	<ul style="list-style-type: none"> Constant display of detected frame errors Distinction between active and passive error frames (0 ... >50.000)
Protocol monitor	<ul style="list-style-type: none"> All supported baud rates Online receipt of CAN message frames, including filtering Single or cyclic transmission of CAN message frames
Test record	Comprehensive, configurable measuring and test record on DIN A4: <ul style="list-style-type: none"> Letterhead with tester and customer contact data Tabular representation of the measured values Graphic representation of the measured values
Export function	<ul style="list-style-type: none"> Measuring data as a configurable CSV file Graphical measured-data representation as a bitmap (.bmp)
Firmware and FPGA configuration	can be updated via USB
CE conformity	
Equipment safety	EN 60950-1: 2003-03
EMC	<ul style="list-style-type: none"> Low-frequency interference emission: EN 61000-3-2: 2000, +A1: 2001, +A2: 2004 High-frequency interference emission: EN 55022: 1998, +A1:2000, +A2:2003 Interference immunity: EN 61000-6-2: 2001

Table 4

Electrical parameters	
Power supply	Via the supplied wide-range power supply pack (9 ... 36 V DC)
Current consumption	0.55 ... 0.15 A
Measuring of the differential voltage	typ. -0.75 V ... 3.00 V
Measuring of the loop resistances	typ. 0 Ω ... 800 Ω
Measuring of the cable length	typ. 0 m ... 500 m <ul style="list-style-type: none"> • 0...100 m: Resolution: 0.5 m, Accuracy: 3 % \pm 1,5 m • 100...500 m: Resolution: 1.0 m, Accuracy: 10 % \pm 10 m • For a signal runtime of: 4.5 ns/m for CAN/CANopen 4.3 ns/m for DeviceNet
Measuring of the CAN supply voltage	0 ... 36 V
Potential difference between the connections CAN bus, USB and oscilloscope	< 50 V DC (or < 71 V AC)
Trigger output for the oscilloscope	BNC socket, electrically isolated, H pulse, approx. 2 bits wide, level approx. 5 V
Mechanical parameters	
Supply voltage connection	Extra-low voltage socket
CAN connection	2 x 9-pin SUB-D connector (also M12 and Open Style via adapter cable)
PC connection	Self-powered device to USB Specification 1.1, electrically isolated
Trigger output for the oscilloscope	BNC socket, electrically isolated
Housing	Aluminium scheel housing
Temperature range	<ul style="list-style-type: none"> • Operation: 5 °C ... 40 °C • Storage:-20 °C ... 60 °C
Humidity	<ul style="list-style-type: none"> • Operation: 20 % ... 80 % (non-condensing) • Storage:20 % ... 80 % (non-condensing)
Degree of protection of the housing	IP20 to EN 60529
Dimensions	170 mm x 125 mm x 40 mm
Weight	Approx. 570 g

SCOPE OF DELIVERY

The scope of supply of the CAN-Bus Tester 2 for bus systems CAN and CANopen comprises the following:

- CAN-Bus Tester CBT2
- CAN bus accessories:
 - SUB-D adapter cable
 - Open style adapter cable
 - M12 adapter cable
 - CAN bus M12 T piece
 - CAN-Bus M12 terminator
 - Adapter board (for simple connection of oscilloscope probes)
 - Open style adapter
- Power supply:
 - AC/DC adapter:
 - Type: Desk power pack
 - Input voltage: 100 ... 240 V, 50 Hz ... 60 Hz
 - Output voltage (DC): 24 V, 500 mA,
 - Connection cable: 2 m length with extra-low-voltage plug
 - Mains power cable (1.8 m):
 - Country variants: Europe, Great Britain, U.S.A./Japan, (Australia possible)
- Further accessories:
 - SUB-D shorting plug
 - Open style shorting plug
 - M12 shorting plug
 - USB cable (3 m)
 - BNC cable (1.5 m)
- User Manual
- Product CD with USB driver and application software
- Suitcase



Figure 33 Screen shots CBT2 PC-Software

7.3 CANobserver®

Once the plant stands still, it is too late in most cases. In order to initiate steps against this, both the components of the plant and the supply network have to be maintained continuously. The operation parameters of the bus system degrades due to wear. GEMAC's CANobserver® diagnoses such changes while day-to-day functioning continues and informs the plant operator.

The CANobserver® is a diagnose tool that's used for physical and logical long-term monitoring of CAN-Bus plants. It has been planned as a stationary supplement of the CAN-Bus Tester 2.

The CANobserver® is implemented into the network permanently and monitors the data transfer continuously. This is the only means of safeguarding a future-oriented maintenance. VDI/VDE has recognized this necessity as well. The new guideline 2184, published in 2007, explains how plant operators can guarantee a reliable functioning and maintenance of their Field Bus systems.

Features:

- Bus systems:
 - CAN, CANopen, DeviceNet
- Baud rates (5 kbit/s ... 1 Mbit/s)
- Monitoring physical
 - Quality level (0 ... 100 %)
 - Disturbance-free voltage range
 - Rising and falling edges
- Monitoring logical
 - Active/Passive error frames, overload frames, acknowledge errors
- Continuous monitoring
 - Bus status, bus traffic load, CAN supply voltage
- User-friendly browser-based configuration and analysis
- Control point connection via SNMP
- Maintenance without PC, continuous recording up to 4 years



Figure 34 CANobserver®

TECHNICAL SPECIFICATIONS

General parameters and overview of functions	
Use (CAN type)	CAN (ISO11898-2), CANopen, DeviceNet (EN 50325-2)
Baud rates	All baud rates according to the particular CAN type
Station overview	Automatically according to the particular CAN type
Bit sampling	64-fold
Quality level	Signal quality level (0 ... 100 %)
Disturbance-free voltage range	0 ... 4 V, resolution 50 mV
Edges	Edge steepness (in 1/64th of the bit width)
Bus status	Bus traffic detection (display: dominant, recessive, not defined, bus traffic)
Bus traffic load	Permanent display of the bus traffic load (0 ... 100 %)
Error logging	Active error frames Passive error frames Overload frames Acknowledge errors Failure to reach a critical quality level (adjustable) Failure to reach a critical disturbance-free voltage range (adjustable) Exceeding of a critical rising edge (adjustable) Exceeding of a critical falling edge (adjustable)
Error indicator	All logged errors (permanent/current) displayed via LEDs
Error output	Freely programmable
Export	Recorded measurements exportable in XML format for processing with CAN-Bus Tester 2 - Application software
Electrical parameters	
Power supply	Via the supplied wide-range power supply pack (9 ... 36 V DC)
Measuring of the differential voltage	typ. -0.75 V ... 3.00 V
Measuring of the CAN supply voltage	0 ... 36 V
Error output	Potential-free, max. 30 V DC
Mechanical parameters	
CAN connection	9-pin SUB-D connector
Network connection	10/100 MBit Ethernet IEE 802.3u, RJ-45 (8P8C) LAN connector
Housing	Aluminum plate housing for top hat rail mounting, degree of protection: IP20
Temperature range	Operation: 5 ... 40 °C, storage: -20 ... 60 °C
Dimensions	50 mm x 125 mm

Table 5

Reference list

Domestic

Acterna, Eningen
AMCON Electronic GmbH, Hartha
ATMEL Deutschland GmbH, Heilbronn
BD Sensors, Thierstein
Bernstein AG, Porta Westfalica
Bison Palfinger GmbH, Löbau
Carl-Zeiss GmbH, Oberkochen
EADS, Ulm
Endress + Hauser GmbH, Maulburg
Feinmess Suhl GmbH, Suhl
Fresenius HemoCare GmbH, Schweinfurt
Fresenius Medical Care GmbH, Bad Homburg
Grimme Landmaschinen GmbH, Damme
HAMM AG, Tirschenreuth
Heidelberger Druckmaschinen AG, Heidelberg
Hoppe Boardmesstechnik GmbH, Hamburg
IAV GmbH, Chemnitz
Indusol GmbH, Gera
IXXAT Automation GmbH, Weingarten

Jena-Optronik, Jena
Jungheinrich AG, Hamburg
Kirow Leipzig Kranbau Eberswalde AG, Leipzig
Lenord, Bauer & Co GmbH, Oberhausen
Polytec GmbH, Waldbronn
PROMECON GmbH, Barleben
Roche Diagnostics, Mannheim
Schneeberger GmbH, Gräfenau, Höfen
Sennheiser electronic, Wedemark
Softing AG, München
Still AG, Hamburg
Teupen Maschinenbaugesellschaft, Gronau
Trumpf Medizin Systeme GmbH, Saalfeld
VacuTec Messtechnik GmbH, Dresden
Wagner Pflanzentechnik GmbH, Friedelsheim
Wincor Nixdorf Int., Paderborn

International

Canon Inc., Utsunomiya / Japan
CEAT srl, Mailand / Italien
Computer Optical Products Inc. / USA
Dewit bv, Soestduinen / Niederlande
DSF Technologies, Biot Frankreich
Ericsson, Wien / Österreich
Fara New-Tech Development Co., Xian / China
Gurley Precion Instruments / USA
HIWIN Microsystems Corp. / Taiwan
Lika Electronic SNC, Carré / Italien
Linreco AB, Spanga / Schweden
Manitou / Frankreich
OMEGA Dynamic, Rueil-Malmaison / Frankreich
Renishaw PLC, Wotton-under-Edge / England
Sankyo Seiki, Nagano / Japan
Sensing / Spanien
Sensor Control Nordic AB, Sollentuna / Schweden
Solartron Metrology Ltd., Bognor Regis / England
Sony Manufacturing, Isehara / Japan
Tamagawa Seiki Co., Nagano / Japan
ThyssenKrupp BV, Krimpen / Niederlande